

REACH-IN FREEZER (0°F)

Model: DL1FE

Designer line

1-Section Extra-Wide Reach-In Freezer

DL1FE - Stainless steel front, aluminum end panels and interior
DL1FE-SA - Stainless steel exterior, aluminum interior
DL1FE-SS - Stainless steel exterior and interior



Options and Accessories

(upcharge and lead times may apply)

Stainless steel case back	Special electrical req. (consult factory)
Add'l epoxy-coated steel shelves	Correctional Facility Options
Chrome or stainless steel shelves	<ul style="list-style-type: none"> One way security screws
Pan slide assemblies	<ul style="list-style-type: none"> Locking hasp (lock not included)
Expansion valve system	<ul style="list-style-type: none"> Stainless steel mesh cover
Casters	<ul style="list-style-type: none"> Coverless hinges
Custom laminates	

Consult factory for other model configurations, options and accessories.

Continental[®]
Refrigerator

Toll-Free: 800-523-7138
 Phone: 215-244-1400
 Fax: 215-244-9579

539 Dunksferry Road
 Bensalem, PA 19020
www.continentalrefrigerator.com

Project Name:

Model Specified:

Location:

Item No:

Quantity:

AIA #:

SIS #:

Standard Model Features

REFRIGERATION SYSTEM

Self contained, performance-rated "plug" refrigeration system
 Environmentally-safe, R-404A refrigerant
 Refrigeration system is readily accessible on top of cabinet, separate from the "food zone"
 Automatic, hot gas condensate evaporator

CABINET ARCHITECTURE

3" non-CFC polyurethane foam insulation
 Smooth, polished chrome workflow door handle
 Cam action, lift off hinges
 Self-closing door
 Magnetic snap-in door gasket
 Cylinder lock in door
 Heavy-duty, epoxy-coated steel shelves
 Adjustable 6" stainless steel legs

MODEL FEATURES

LED interior lighting
 Electronic controller w/digital display & hi-low alarm
 Top and side air distribution ducts
 Cabinet upper side panels and refrigeration "plug" system can be removed and reinstalled at job site
 Automatic electric defrost
 Rehinging of door (in the field)

APPROVAL:

Model Specifications

DIMENSIONAL DATA

Net Capacity (cu. ft.)	22 (623 cu l)
Width, Overall (in.)	28 1/2 (724 mm)
Depth, Overall (in.) (incl. handle)	35 3/8 (899 mm)
Depth (in.) (less door)	32 (813 mm)
Depth (in.) (door open 90°)	58 (1473 mm)
Clear Door Width (in.)	21 7/8 (556 mm)
Clear Door Height (in.)	58 5/8 (1489 mm)
Height, Overall (in.) (incl. 6" legs)	83 1/4 (2115 mm)
No. of Doors	1
No. of Shelves	3
Shelf Area (sq. ft.)	20.4 (1.9 sq m)
Tray Slide Capacity	24

REFRIGERANT DATA

Condensing Unit Size (H.P.)	1/3
Capacity (BTU/Hr)*	1590

ELECTRICAL DATA

Voltage (int'l)	115/60/1 (220/50/1)
Feed Wires (incl. ground)	3
Total Amps (int'l)	6.3 (3.8)
Defrost Amps (int'l)	4.3 (2.2)
10 ft. Cord/Plug [attached] (int'l)	Yes (No)

SHIPPING DATA

Height - Crated (in.)	85 1/2 (2172 mm)
Width - Crated (in.)	31 5/8 (803 mm)
Depth - Crated (in.)	42 (1067 mm)
Volume - Crated (cu. ft.)	65 (1841 cu l)
Weight Std - Crated (lbs.)	355 (161 kg)
Weight SS - Crated (lbs.)	415 (188 kg)

* Rating @ -15°F evaporator, 90°F ambient

Figures in parentheses reflect metric equivalents rounded to the nearest whole unit.



Equipped with one NEMA-5-15P Plug
(varies by country)

Continental
Refrigerator

Toll-Free: 800-523-7138
Phone: 215-244-1400
Fax: 215-244-9579

539 Dunkserry Road
Bensalem, PA 19020
www.continentalrefrigerator.com

Due to our continued efforts in developing innovative products, specifications subject to change without notice.



MADE IN THE U.S.A.

© Copyright 2020. Continental Refrigerator.
A Division of National Refrigeration & Air Conditioning Products, Inc.

Model Plan Views

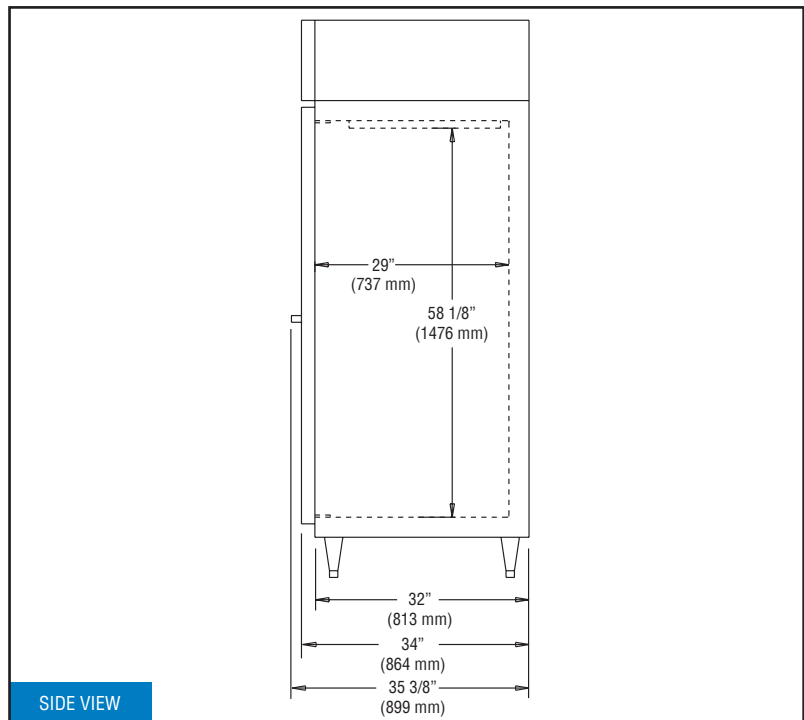
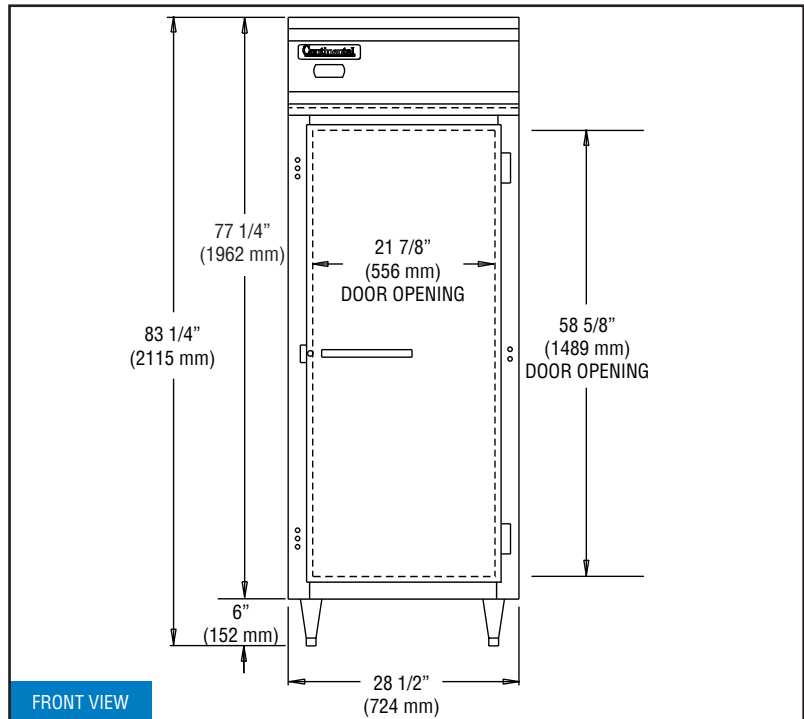

IMPORTANT NOTE: If the cabinet is located directly against a wall and/or under a low ceiling, a minimum clearance of 12" is required on top and 3" on sides and rear.